

SCHARFEN

Fully automatic food slicer with conveyor belt

Model VA 4000 AT

Model VA 4000 AT

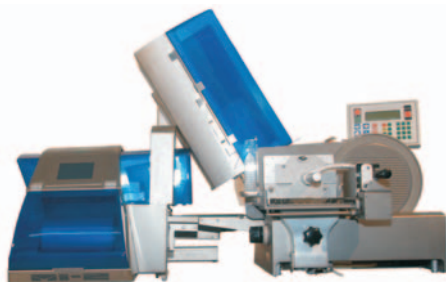
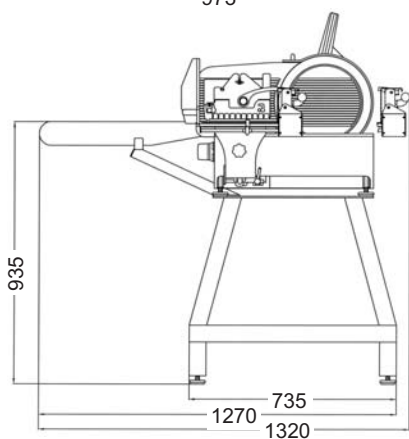
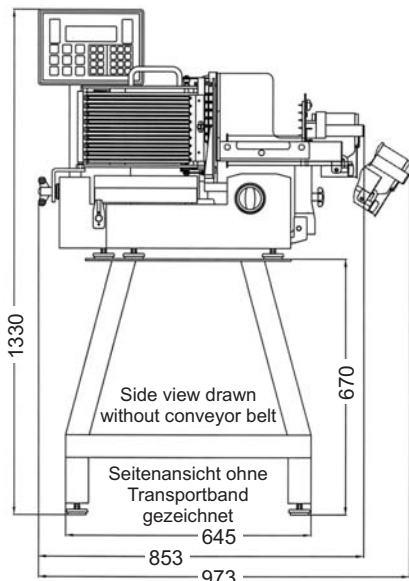

**Model VA 4000 P
with wrapping machine**

Technical Data

counter space required

(l x w): 735 x 645 mm

overall dimensions

(l x w x h): 1270 x 853 x 1330 mm

conveyor belt

(l x w): 880 x 280 mm

carriage

(l x w): 275 x 360 mm

weight app. 130 kg

voltage

3-phase or 1-phase, voltage and cycles as required

power consumption 0,6 kW

sound level <70 dB (A)

blade

330 mm Ø, hollow-ground, hard chromed, stay sharp quality

slice thickness

0 - 10 mm (infinitely variable)

cutting length

255 mm

cutting height

195 mm

capacity

speed of carriage is infinitely variable, about 25 - 55 strokes per minute.

precise slicing

because of separate gear motor for blade rotation. Therefore 98 % power transmission by direct gear drive.

Model VA 4000 AT is available in following special executions:

Tefloned execution

ideal for slicing cheese. Carriage, thickness plate, blade guard and blade are tefloned. Easy and precise slicing, no smearing and no sticking. Further advantage: quick and easy to clean with dry cloth. All other technical details as above.

With **large carriage** (l x w): 275 x 530 mm, ideal for large food products. All other technical details as above. Special executions upon request.

With **claw end piece holder** instead of standard end piece holder.

Model **VA 4000 AT** can be prepared for connection to an **interleaver**. Further information upon request.

Execution **without conveyor belt** see leaflet model **VA 4000**.

Special execution model **VA 4000 P** without conveyor belt but prepared for connection to an **automatic wrapping machine** and/or **interleaver**. With receiving fork for transportation of the sliced portion to the wrapping machine, with or without tray. Further information upon request.

stacking

1 - 2 stacks per portion adjustable, distance between the portions, infinitely variable, maximum height of stack 50 mm

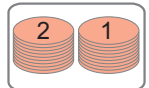

shingling down

shingling distance down up to 30 mm (infinitely variable), per portion 1 - 2 shingled portions side by side, distance between the portions infinitely variable

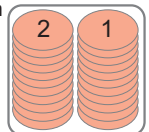

shingling cross

shingling distance down and cross up to 30 mm (infinitely variable), per portion 1 - 9 shingled portions side by side, distance between the portions infinitely variable

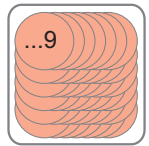

circle shingling

circle shingling with a diameter of up to 230 mm, distance between portions infinitely variable

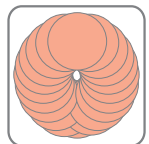

99 programmable slicing programmes

easy calling up by entering the PLU-number with max. 3 digits between 001 and 999. With every PLU-number there are programmed all necessary slicing data, such as name of article, speed of the carriage, slice thickness and all parameter for stacking, shingling down and cross or circle shingling.

Security and hygiene

model VA 4000 AT corresponds to legal security and hygienic requirements. Sharpening device is removable. Carriage can be tilted aside for cleaning. Conveyor belt, chain frame and stacking device are removable.

Machine body and all metal parts in contact with food are made of **stainless steel**.